

## Ice Cuber 46kg/24h with 25kg bin - Air-cooled (Marine)

ITEM # \_\_\_\_\_

MODEL # \_\_\_\_\_

NAME # \_\_\_\_\_

SIS # \_\_\_\_\_

AIA # \_\_\_\_\_



730588 (CIM50AB)

Ice maker, cube, 46kg/24h with 25kg collection bin included - air cooled (Marine)

### Short Form Specification

**Item No.** \_\_\_\_\_

AISI 304 stainless steel exterior. Food grade ABS interior. Stainless steel spray arms removable without the use of tools. Fully automatic in operation. Efficient air cooling system. Suitable for gravity drain only. Flexible water supply and drain hoses. A spray system produces solid, crystal clear ice cubes.

Rated output is at an ambient air temperature of 21°C and water supply temperature of 15°C.

Self-contained storage bin capacity: 25 Kg.

### Main Features

- Compact dimensions of the ice cubers make them highly suitable for any location, particularly those where space is at a premium.
- The ice-making method (spray layering) guarantees crystalline, compact, hygienically pure ice cubes that are resistant to melting.
- Model available in air-cooled version.
- Ice cube cone shape with the trunk sides slightly squashed.
- Bin integrated as standard.
- Compliant to CE requirements for safety.
- Fully automatic in operation.
- Operates over a wide range of temperatures.
- Suitable for gravity drain only.
- Rated output is at an ambient air temperature of 21°C and water supply temperature of 15°C.

### Construction

- Reliability guaranteed by the quality of the construction materials used (plastic flap on the front, top and sides in 304 AISI stainless steel) and the sophisticated product and process technology involved.
- The sprayers are easy to take away, permit a simple flowing and prevent limestone formation.
- Internal ice cubes container in ABS.
- Plug as standard (schuko type).
- AISI 304 stainless steel exterior.
- Stainless steel spray arms removable without the use of tools.
- Adjustable feet 110-150 mm.
- Environmentally friendly: R452a as refrigerant gas.

APPROVAL: \_\_\_\_\_

**Side**

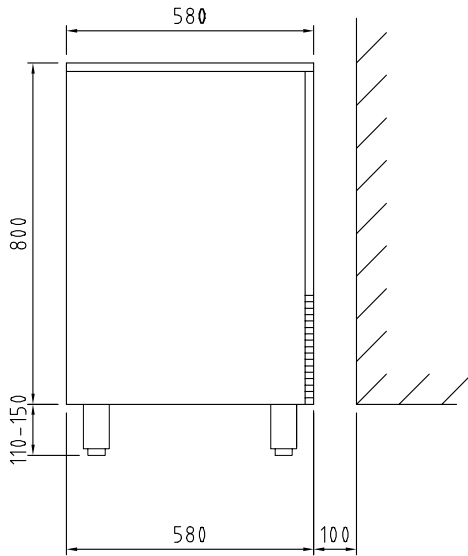

**Top**

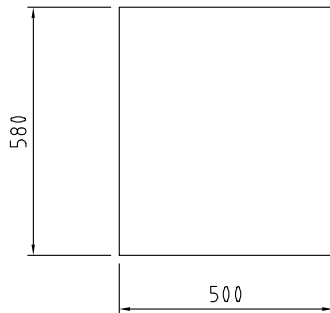

- CWI1** = Cold Water inlet 1 (cleaning)
- D** = Drain
- EI** = Electrical inlet (power)

**Front**

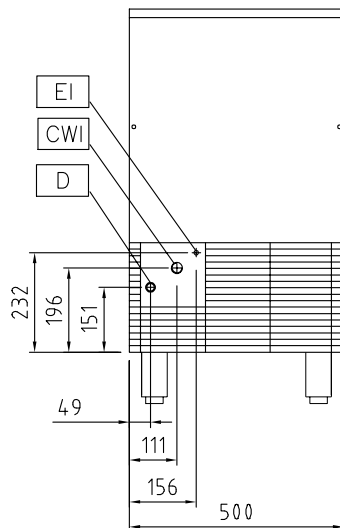

### Electric

<b>Supply voltage:</b>	
730588 (CIM50AB)	230 V/1N ph/60 Hz
<b>Electrical power max.:</b>	0.5 kW

### Capacity:

<b>Bin capacity:</b>	25 kg
----------------------	-------

### Key Information:

<b>External dimensions, Width:</b>	500 mm
<b>External dimensions, Depth:</b>	580 mm
<b>External dimensions, Height:</b>	910 mm
<b>Net weight:</b>	56 kg
<b>Output:</b>	46 kg/day
<b>Kind of cube:</b>	Ice Cube 18 g

### Sustainability

<b>Noise level:</b>	54,2 dBA
<b>Refrigerant type:</b>	R452A